

1. Product Description

Nexto Series is a powerful and complete Programmable Logic Controller (PLC) with unique and innovative features. Due to its flexibility, smart design, enhanced diagnostics capabilities and modular architecture, Nexto can be used for control systems from medium or high-end applications. Due to its compact size and superior performance, Nexto can also be used for small automation systems with time critical requirements.

MasterTool IEC XE is a complete tool for programming, debugging and performing configuration and simulation of user applications. Based on a concept of being integrated, flexible and easy to use, this software provides five programming languages defined by IEC 61131-3 standard: Structured Text (ST), Sequential Function Chart (SFC), Function Block Diagram (FBD), Ladder Diagram (LD) and Continuous Function Chart (CFC). MasterTool IEC XE allows the use of different languages on the same application, providing to the user a powerful way to organize the application and to reuse codes used in previous applications.

This product offers features for every stage of an automation application, starting from initial graphical architecture topology analyses, passing through a programming environment that supports IEC 61131-3 languages and a realistic simulation tool, where the user can verify application's behavior before running in a real system and ending in a complete diagnostics and status visualization interface.

MasterTool IEC XE also offers two different protection schemes as application security features: IP Protection and Secure PLC Login. IP Protection is targeted to protect user's intellectual property, allowing the user to protect the complete project and files by defining a password to access them. This means that these files will be available (both read and write operations) only after unlocking them with the correct password. Secure PLC Login provides a way to protect the user application from any unauthorized access. By enabling this feature, Nexto CPU will request a user and a password before performing any available command in MasterTool IEC XE and Nexto CPU, as stopping, programming and forcing of outputs in the target CPU.

MasterTool IEC XE allows the use of fieldbus interfaces in an easier way than ever seen before. The user does not need any special software to configure fieldbuses anymore, because MasterTool IEC XE covers this requirement providing a unique tool reducing engineering time and making applications more simple.

In order to increase user's productivity, some important features are also available: Module Printing which is a report generation of every module specific parameters and application general settings, Logic Printing which is a report generation of all application code, Enhanced Project Verification which helps user to check several different conditions during programming, like programming syntax, power supply module current consumption, placement rules for Nexto modules, modules parameters and settings, Real Time Debugging which provides useful way to check the application step-by-step, verify variables values or add and remove breakpoints during Nexto CPU programming.



2. Technical Description

2.1. MasterTool IEC XE Versions

MasterTool IEC XE has four distribution versions, each one with an optimized portfolio in accordance with the user's needs.

- **Lite:** free programming software that allows the programming and project loading of up to 320 I/O points
- **Basic:** software that allows the programming and project loading of up to 2048 I/O points
- **Professional:** programming software for all Nexto Series CPUs
- **Advanced:** programming software with tools for large scale applications using half-cluster redundancy

Each one of these versions has unique characteristics, purposes and features for each specific objective.

	Lite	Basic	Professional	Advanced
Free version	Yes	No	No	No
Available languages:	5	5	5	5
Structured Text (ST)	Yes	Yes	Yes	Yes
Sequential Function Chart (SFC)	Yes	Yes	Yes	Yes
Function Block Diagram (FBD)	Yes	Yes	Yes	Yes
Ladder Diagram (LD)	Yes	Yes	Yes	Yes
Continuous Function Chart (CFC)	Yes	Yes	Yes	Yes
Rack expansion support	No	Yes	Yes	Yes
Rack expansion redundancy support	No	No	Yes	Yes
Ethernet expansion support	No	No	Yes	Yes
Ethernet expansion redundancy support	No	No	Yes	Yes
PROFIBUS support	No	Yes	Yes	Yes
PROFIBUS redundancy support	No	No	Yes	Yes
Half-Cluster redundancy support	No	No	No	Yes
Event grouping support	Yes	Yes	Yes	Yes
DNP3 protocol support	No	Yes	Yes	Yes
IEC 60870-5-104 protocol support	Yes	Yes	Yes	Yes
IEC 61850 protocol support	No	Yes	Yes	Yes
Xtorm Ethernet interface redundancy support	No	Yes	Yes	Yes
CPU redundancy support	No	No	No	Yes
Limitation of the number of local I/O points	Yes	Yes	No	No
Maximum number of local I/O points	320	2048	Unlimited	Unlimited

Table 1: Versions Features

Notes:

Continuous Function Chart (CFC): The CFC language has two editors. In the first, all functions are enumerated with a unique execution order. In the second, the user can edit logic groups in individually enumerated pages – therefore it is called *Page Oriented*.

Fieldbus support: Nexto Series architectures use the PROFIBUS DP as the fieldbus.

Maximum number of local I/O points: For this limit, only I/O points present in the CPU rack are considered, not considering I/O points in remote ones. In the case of Advanced and Professional licenses, the limit will be the memory occupation %I and %Q in each CPU model.

	Lite	Basic	Professional	Advanced
CODESYS Control Win V3 x64	Yes	Yes	Yes	Yes
NL717	Yes	Yes	Yes	Yes
XP300	Yes	Yes	Yes	Yes
XP315	Yes	Yes	Yes	Yes
XP325	Yes	Yes	Yes	Yes
XP340	Yes	Yes	Yes	Yes
XP350	Yes	Yes	Yes	Yes
XP351	Yes	Yes	Yes	Yes
NX3003	Yes	Yes	Yes	Yes
NX3004	Yes	Yes	Yes	Yes
NX3005	Yes	Yes	Yes	Yes
NX3008	Yes	Yes	Yes	Yes
NX3010	Yes	Yes	Yes	Yes
NX3020	No	Yes	Yes	Yes
NX3030	No	No	Yes	Yes
NX3035	No	No	Yes	Yes
NX5100	Yes	Yes	Yes	Yes
NX5101	Yes	Yes	Yes	Yes
HX3040	Yes	Yes	Yes	Yes

Table 2: Supported Products

Note:

CODESYS Control Win V3 x64 support: CODESYS Control Win V3 x64 will be supported directly by CODESYS. Only for DEMO Mode use.

2.2. Data for Purchase

2.2.1. Included Items

The MasterTool IEC XE software is sold as a service, with the contract and the respective license sent in digital format to the customer. Get in touch with the Altus commercial department if physical media is required with the product.

2.2.2. Product Code

The following codes shall be used for product purchase:

Code	Description
MT8500 Lite	MT8500 Lite
MT8500 /BASIC/S	MT8500 Basic
MT8500 /PRO/S	MT8500 Professional
MT8500 /ADV/S	MT8500 Advanced

Table 3: Product Code

3. Product Features

3.1. IEC 61131-3 Programming Languages

MasterTool IEC XE offers all editors defined in the IEC standard for application development: Structured Text (ST), Sequential Function Chart (SFC), Function Block Diagram (FBD), Ladder Diagram (LD) and Continuous Function Chart (CFC).

All editors were specially designed to ensure optimal handling. Some examples:

- When working in FBD or LD you can freely switch between these editors
- Language elements can either be entered directly or dragged into the editor from a tool box
- MasterTool IEC XE offers an intelligent input assistant and an extended “Autocomplete” functionality
- Standard language constructs of ST language, such as *IF* and *FOR*, can be folded and unfolded in the text editor
- Auto declare for constructs such as *IF ... END_IF* and *WHILE ... END_WHILE*
- Time monitoring mechanism for performed steps as well as the diagnostics functionality
- Steps and transitions in the SFC editor and all elements in the CFC editor can be encapsulated in macros
- Automatic declaration of variables
- Graphic table for declaration of variables

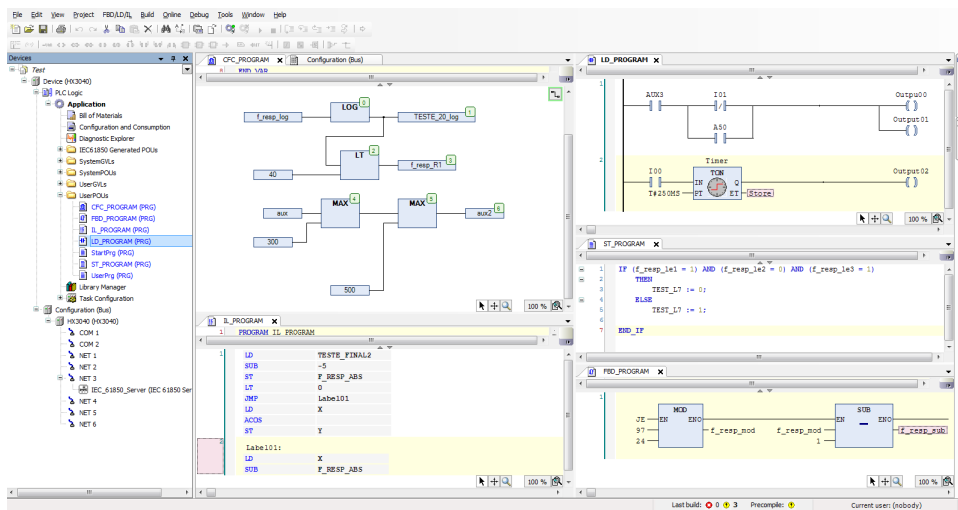

Figure 1: IEC 61131-3 Programming Languages

3.2. Editors for Project Configuration and Hardware Configuration

With the aid of special editors, a project can be easily configured in MasterTool IEC XE. The graphical tool allows a fast and comprehensive way to configure the system where the user just needs to drag from library products the selected module and drop it in the backplane to add them to the application. Additionally, the user has the complete visualization of the application architecture with the physical position and module information.

The configuration of standard communication protocols, such as DNP3, IEC104 and MODBUS, are integrated in the programming tool. This feature enables the user to set all configuration parameters in a single place, avoiding the need of switching between different software tools.

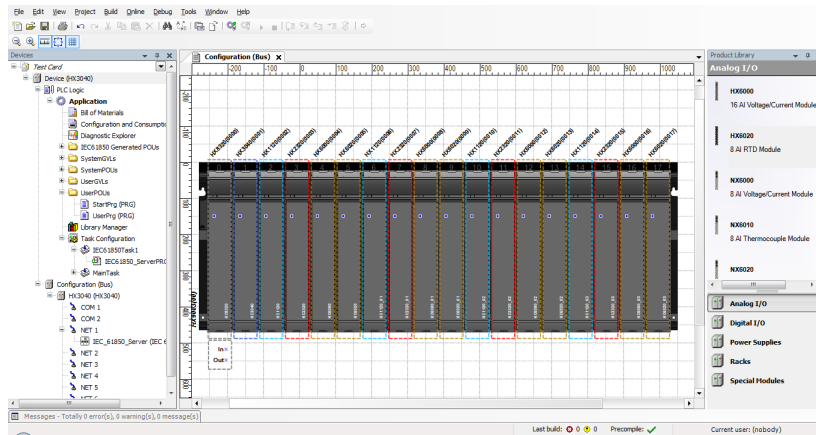

Figure 2: Editors for Project Configuration and Hardware Configuration

3.3. Object Oriented Programming

MasterTool IEC XE offers object-oriented programming with the known advantages from modern high-level languages such as JAVA or C++, such as the use of classes, interfaces, methods, inheritance and polymorphism. The IEC function blocks are seamlessly extended and the extensions are available to all engineering aspects. Object-oriented programming offers great advantages to the user, for example, when reusing existing parts of the application or when working on one application with several developers.

3.4. Online, Debugging and Commissioning Features

The code generated from the application is downloaded onto the target device with a single mouse click. Once MasterTool IEC XE is online, it offers many important functions for fast and efficient debugging, testing and commissioning.

The values of declared variables are displayed directly in the program code. These values can be changed or forced without difficulty. By setting breakpoints and then stepping through the code line by line, errors can easily be detected. Breakpoints in MasterTool IEC XE can be assigned to certain conditions to achieve even more precision in the debugging process. Using Run to Cursor feature, the user can follow the execution of the application through a complete cycle.

If the application code is modified, it is recompiled, and then loaded again without stopping the controller. Changes to several POU's (Program Organization Unit), variables or data types are also possible. This functionality is called online change. Shorter development cycles and a faster production process lead to reduced costs and increased competitiveness.

The trace is a very useful tool when the user wants to record data or even trigger events for testing or commissioning purposes. This stored data, which is completely integrated in MasterTool IEC XE, can also be used to visualize application data.

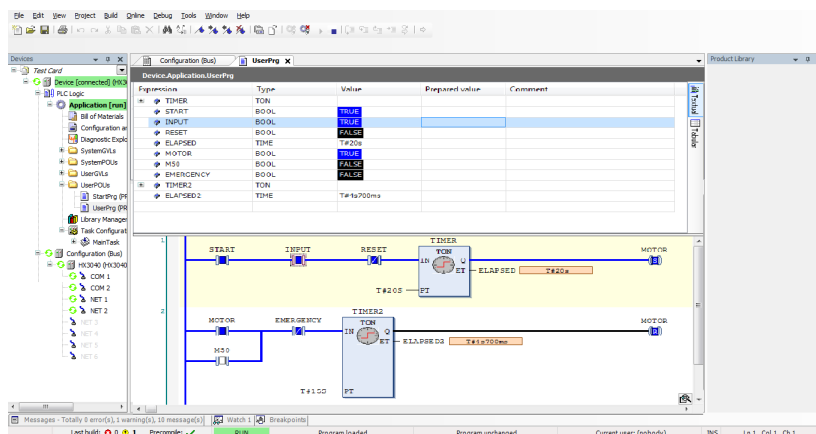

Figure 3: Online, Debugging and Commissioning Features

3.5. Simulation

The simulation tool allows the user to evaluate and test logic and algorithms. This feature enables the development and test of user applications without the need of a connected controller. It is also interesting for training, documentation and test cases evaluation. Since it is a simulator, some limitations may apply, such as not being able to test the communication interfaces, and consequently the application will be completely tested just when loaded onto the controller.

3.6. User Documentation & Help Files

Since programming and configuring a CPU according to IEC 61131-3 standard is a complex task, MasterTool IEC XE offers an extensive help page with many hints and descriptions in order to guide and serve as a first knowledge and troubleshooting base while designing the logic codes or using any software features. Besides, this help is available in different languages according to installation options.

As part of user documentation, MasterTool IEC XE can print out user application documents, such as bill of materials (BOM), POUs, bus configuration, tag and description, among other options.

3.7. Advanced Diagnostics

One of the key innovative features of Nexto Series is the extensive support of diagnostics. This idea comes from requirements of large and complex applications, where the correct use of such information is important for maintenance, troubleshooting and to predict potential issues. This feature is also present in MasterTool IEC XE where user can access the complete diagnostics structures via watch windows, when connected to a CPU.

3.8. Function Block Libraries

MasterTool IEC XE has several function block libraries ready to be used. Functions such as process variable handling, mathematic functions and timers are some examples of functions that are brought together with MasterTool IEC XE .

3.9. Docking View

The *Docking View* technology allows the user to customize MasterTool IEC XE environment to meet personal needs. This feature provides a user friendly interface to maximize the experience with the software tool.

3.10. Languages

MasterTool IEC XE software is available in a few languages. After the installation, the interface assumes the language of Computer Operating System. The language can be changed after installation without the need for resettlement.

3.11. Compatibility with Other Product

Versions of MasterTool IEC XE are not compatible with all versions of controllers. To know which version is compatible, the technical datasheet document of each controller should be consulted.

3.12. Minimum and Recommended Requirements

MasterTool IEC XE presents as minimum and recommended requirements for its installation and utilization the following specs:

MasterTool IEC XE	
Platform	PC with operating system: Until version 3.05: Windows XP® (32 bits), Windows Vista® (32 bits), Windows 7 SP1® (32 bits or 64 bits) or Windows 8.1® (64 bits) From version 3.10 until version 3.23: Windows 7 SP1® (32 bits or 64 bits) or Windows 8.1® (64 bits) From version 3.30 until version 3.35: Windows 7 SP1® (32 bits or 64 bits), Windows 8.1® (64 bits) or Windows 10® (64 bits) Version 3.40: Windows 8.1® (64 bits), Windows 10® (64 bits) or Windows 11® (64 bits) From version 3.50: Windows 10® (64 bits) or Windows 11® (64 bits)
Processor	2.5 GHz (recommendable)
Disk Space	2 Gbyte (minimum), 12 Gbytes (recommended)
RAM	4 Gbytes (minimum), 16 Gbytes (recommended)
Resolution	1024 x 768 (recommended)
Language	Any language

Table 4: Minimum and Recommended Requirements for Installation and Operation

Note:

Requirements: As a rule, PCs that fill the minimum requirements can be used for non-redundant applications. Redundant applications should use PCs that have at least the recommended settings.

4. Installation

The necessary information about MasterTool IEC XE installation can be found at MasterTool IEC XE User Manual - MU299609.

5. Programming

MasterTool IEC XE allows programming by making use of five different programming languages, five of them being defined by the IEC 61131-3 standard plus one additional language.

5.1. Ladder Diagram (LD)

The programming language *Ladder Diagram* (LD) is a graphical language based on electrical diagrams representing interconnected contacts and coils, highlighting the energizing flow between the elements. It is used to describe the behavior of programs, function blocks, and functions, in addition to steps, actions and transitions in SFC language.

The language is basically a technique that uses the logic design by using relays. Such diagrams were already used to document relay panels even before the existence of CPUs. The basic elements are usually open and closed contacts, and relay coils. For the operation, the elements must be connected in such a way that they link a vertical bar on the left, which represents a powered bus, with the right bar, which represents the ground. These diagrams were called ladder due to their format.

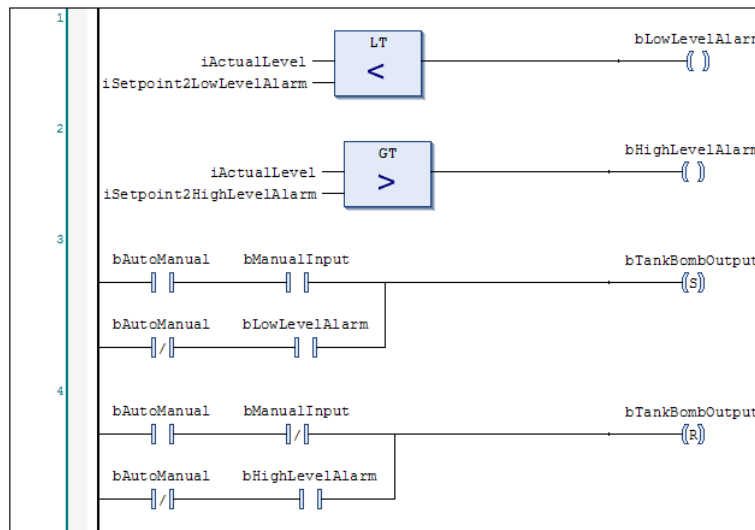

Figure 4: Ladder Diagram (LD)

5.2. Structured Text (ST)

The programming language Structured Text (ST) is a high-level textual language, as seen by its name, with syntax similar to Pascal (ISO 7185). It was developed specifically for industrial control and it is used to describe the behavior of programs, function blocks, and functions, in addition to steps, actions and transitions in SFC language. The language is flexible and easy to be learned by software developers in general.

The ST has common commands in structured languages such as conditional testing and selection commands, as well as distinct types of repeating loops. It also has specific commands for mathematical and logical operations without the need of function calls.

It is vital to have some knowledge of this language's syntax, since variable declarations are made through it, even when the programmer's graphic features are used. For users that do not wish to use ST language, MasterTool IEC XE offers a table for variables graphical declaration and also the auto-declaration option.

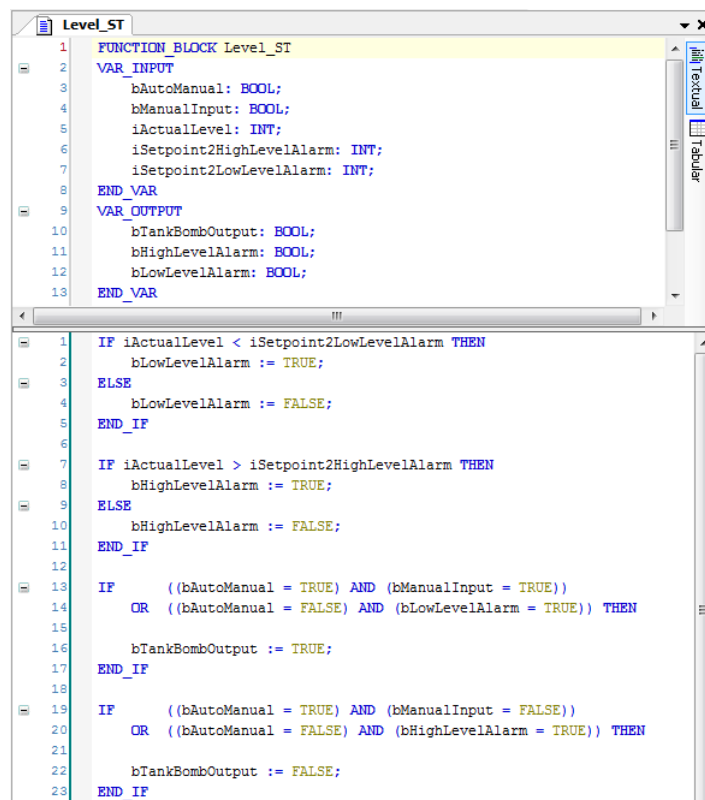

```
1 FUNCTION_BLOCK Level_ST
2 VAR_INPUT
3     bAutoManual: BOOL;
4     bManualInput: BOOL;
5     iActualLevel: INT;
6     iSetpoint2HighLevelAlarm: INT;
7     iSetpoint2LowLevelAlarm: INT;
8 END_VAR
9 VAR_OUTPUT
10    bTankBombOutput: BOOL;
11    bHighLevelAlarm: BOOL;
12    bLowLevelAlarm: BOOL;
13 END_VAR
14
15 IF iActualLevel < iSetpoint2LowLevelAlarm THEN
16     bLowLevelAlarm := TRUE;
17 ELSE
18     bLowLevelAlarm := FALSE;
19 END_IF
20
21 IF iActualLevel > iSetpoint2HighLevelAlarm THEN
22     bHighLevelAlarm := TRUE;
23 ELSE
24     bHighLevelAlarm := FALSE;
25 END_IF
26
27 IF ((bAutoManual = TRUE) AND (bManualInput = TRUE))
28     OR ((bAutoManual = FALSE) AND (bLowLevelAlarm = TRUE)) THEN
29     bTankBombOutput := TRUE;
30 END_IF
31
32 IF ((bAutoManual = TRUE) AND (bManualInput = FALSE))
33     OR ((bAutoManual = FALSE) AND (bHighLevelAlarm = TRUE)) THEN
34     bTankBombOutput := FALSE;
35 END_IF
```

Figure 5: Structured Text (ST)

5.3. Function Block Diagram (FBD)

The programming language *Function Block Diagram* (FBD) is a graphical language based on circuit diagrams representing interconnected blocks, highlighting the flow of signals between the elements. It is used to describe the behavior of programs, function blocks, and functions, in addition to steps, actions and transitions in SFC language.

The concept of a block is any element with inputs that performs a specific processing and then writes the results of the operations to the outputs. The blocks are of two distinct types: function blocks and functions. These two types of POU's differ in that the function blocks keep the value of the local variables between the block calls, which means they must be instantiated and can run state machines, in different execution cycles. The functions perform their functionality and when the execution is finished there is no information left but the result written to the output. In general, although the functions are native of the system, they can also be implemented by the user.

An important characteristic of this language is that the processing runs left-right and top-bottom in the diagram.

The function blocks may also, as well as the functions, be used together with the Ladder diagram, increasing the opportunity of programming with this language.

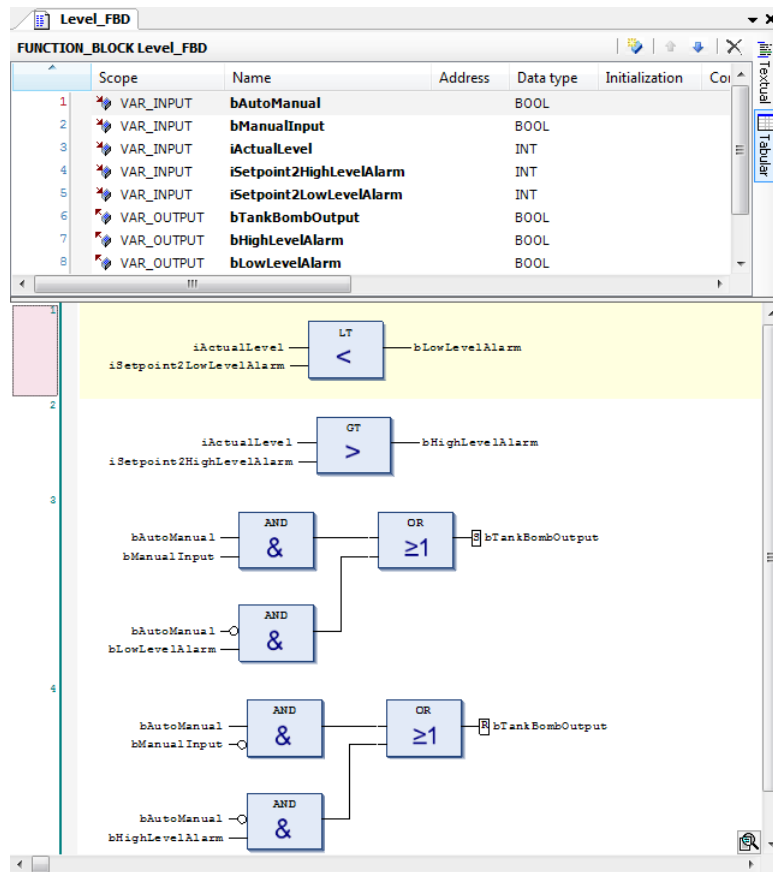

Figure 6: Function Block Diagram (FBD)

5.4. Sequential Function Chart (SFC)

The programming language *Sequential Function Chart* (SFC) is a graphical language based on techniques to describe sequential behavior. The European standard for this type of behavior is described in IEC 848 and is based on Petri Nets. The IEC 61131 standard introduced changes to IEC 848 in order to adjust the SFC to the other standard languages.

Therefore, this language is used to describe the sequential behavior of a system, build program structure, describe the low level of a sequential process, describe the foundations of a batch process, represent data communication and modeling systems which are event-oriented such as state machines.

The language is composed of multiple steps connected by vertical lines, being each step a state in which the program remains until the transition condition described in the connection line between steps is not satisfied.

The flow is from top to bottom, and it is possible to have a branch to return. The actions performed on each step can be continuous or event-oriented such as input or output of the state.

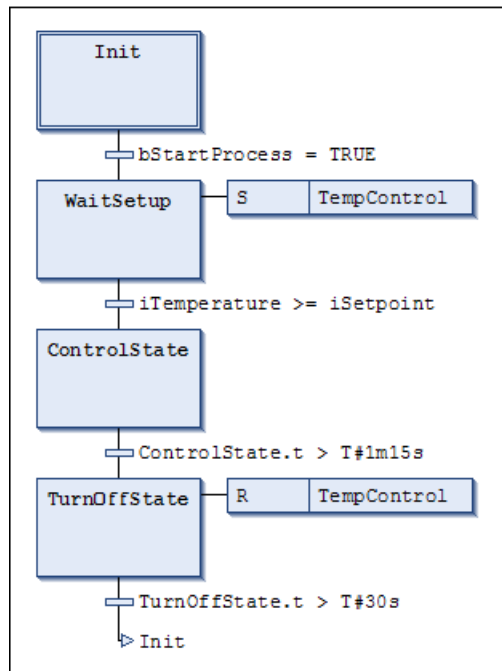

Figure 7: Sequential Function Chart (SFC)

5.5. Continuous Function Chart (CFC)

The *Continuous Function Chart (CFC)* programming language is a graphical language that is not described by the IEC 61131-3 standard, but is complementary to it. It resembles the FBD language, however, when a block is inserted into it, the same must be numbered. This numbering serves to indicate the diagram execution sequence, which facilitates the development and understanding of the diagram, solving this existing problem in the diagram described by the standard.

The CFC – Page Oriented – presents the same features of the regular CFC, but it separates the logics in pages, making the debug and hierarchy of the logic easier.

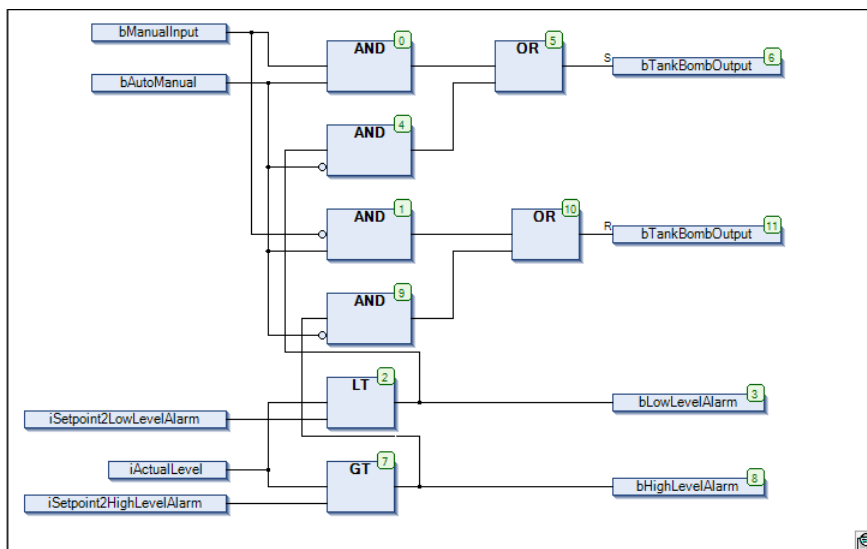

Figure 8: Continuous Function Chart (CFC)

6. Manuals

For further technical details, configuration, installation and programming, the table below should be consulted.

The table below is only a guide of some relevant documents that can be useful during the use, maintenance, and programming of this product.

Code	Description	Language
MU299609	MasterTool IEC XE User Manual	English
MU299048	Manual de Utilização MasterTool IEC XE	Portuguese
MP399609	MasterTool IEC XE Programming Manual	English
MP399048	Manual de Programação MasterTool IEC XE	Portuguese
MU214600	Nexto Series User Manual	English
MU214000	Manual de Utilização Série Nexto	Portuguese
MU223600	Hadron Xtorm Utilization Manual	English
MU223000	Manual de Utilização Hadron Xtorm	Portuguese

Table 5: Related Documents